



TOWER IONIC AIR PURIFIER

ION401



USER MANUAL

IMPORTANT SAFETY INSTRUCTIONS	2
FEATURES	3
OPERATING THE ICONIC AIR PURIFIER	
GETTING STARTED	4
CONTROLS/ SETTINGS	5
MODES OF OPERATION	5
TROUBLESHOOTING	6
CLEANING AND MAINTENANCE	7
CLEANING THE DUST COLLECTION BLADES	7
INSERTING THE DUST COLLECTION BLADES	8
CLEANING THE IONISING WIRES	8
WARRANTY	9
WARRANTY REGISTRATION	10

IMPORTANT SAFETY INSTRUCTIONS

PLEASE READ ALL INSTRUCTIONS CAREFULLY BEFORE OPERATING.

IMPORTANT INFORMATION: Please exercise caution when operating this appliance. Please read the warnings below to prevent any chance of electric shock, injury, fire hazard or damage.

- Do not use the unit outdoors.
- Use only the voltage which has been specified suitable for this product.
- Do not let children operate the unit without adult supervision.
- Always disconnect this product from its power supply before removing internal parts for cleaning.
- Do not touch any parts within the product during operation.
- Do not open the casing of this product, doing so could cause injury and nullify warranty.
- Never wash the product with water or touch it with wet hands.
- Do not use the product in bathrooms, humid areas, fireplaces or place it in proximity to flammable or combustible products.
- Do not use ionic air purifier in the kitchen. Airborne oil cooking may follow air circulation into the product, leaving oil and dust residues on the unit and its surrounding area
- Do not pull the handle of Dust Collection Blades with force, without first releasing the lock, to prevent damaging the product.
- Never operate the ionic air purifier if the plug or cord is damaged. Please contact authorized distributor or qualified personnel to replace the damaged parts.
- Always turn off and unplug this product when not in use over a long period of time. Please hold the secured portion of the plug and remove it from the outlet gently. Do not place the power cord near any heat sources.
- Keep yourself at a safe distance while the unit is running to prevent hairs, fingers, clothing and accessories from getting into the unit.
- Please ensure that the plug has a proper grounding system .
- Please check the product and clean dust regularly to prevent excessive deposits from setting off sparks and causing fire.

This appliance is not intended for use by persons (including children) with reduced physical, sensory or mental capabilities, or lack of experience and knowledge, unless they have been given supervision or instruction concerning use of the appliance by a person responsible for their safety. Children should be supervised to ensure that they do not play with the appliance.

SAVE AND READ THESE IMPORTANT SAFETY INSTRUCTIONS

FEATURES

A Cleaning Rod

B Control Panel

C Casing

D Power Cord

E Base

F Handle

G Dust Collection Blades

H Sliding Lock Button



OPERATION

Getting Started

1. Place this product on a level surface and choose a proper power outlet, referring to safety instructions to ensure safe conduct.
2. Position your ION401 at least 30cm away from the wall.
3. Connect it to the power supply.

Your ION401 is now ready for operation.

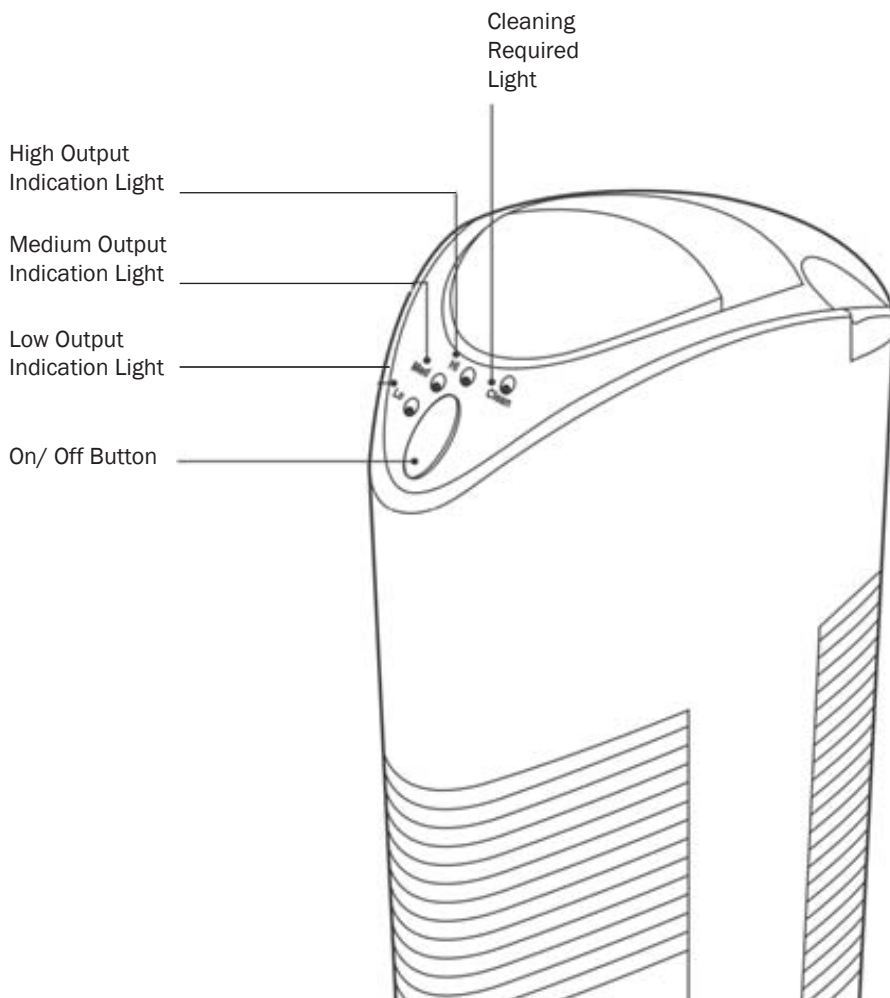

CONTROLS/ SETTINGS

- **ON/ OFF Button**

Turns unit on and off

- **HI**

This indicates that the unit is in high operation mode

- **MED**

This light indicates that the unit is in medium operation mode with 20 second intervals of rest between every 20 seconds of operation.

- **LO**

This light indicates that the unit is in low operation mode with 80 second intervals of rest between every 20 seconds of operation.

- **Cleaning Indicator**

If the red light comes on, this is an indication that your ION401 needs to be cleaned, or it is experiencing other problems. Please refer to the troubleshooting section of this manual for details.

MODES OF OPERATION



Press the **ON/OFF** button to activate the unit and select your preferred mode of operation. Your ION401 starts in HI operation mode by default. Pressing the **ON/OFF** button cycles the mode from **HI** to **MED** to **LO** and **ON/OFF**.

MODE	DESCRIPTION
LO	This economic mode is suitable for small rooms.
MED	This mode is most suited to medium-sized rooms with frequently closed windows.
HI	HI delivers the most negative ions, making it suitable for larger rooms.

Note: if the unit is not cleaned for a long period of time, the **Cleaning Required** light will turn red and the unit will shut down automatically.

TROUBLESHOOTING

Problem	Possible Cause	Trouble-shooting
Indication light is not lit	<ul style="list-style-type: none"> • Power cord is not connected properly. • The ON/ OFF button has not been correctly pressed. • Dust Collection Blades are not installed properly 	<ul style="list-style-type: none"> • Check if plug is loose • Press the ON/ OFF button to ensure unit is switched on. • Re-insert dust collection blades, following instructions.
Red light is lit	<ul style="list-style-type: none"> • Too much dust has been accumulated inside the unit • Collection blades are jarred or have been removed suddenly • Short circuiting may have occurred 	<ul style="list-style-type: none"> • Clean the unit according to instructions. • Remove and re-insert dust collection blades and press ON/OFF button to reset. • Press ON/ OFF button to reset.
Unit is noisy	<ul style="list-style-type: none"> • Too much dust has accumulated inside the unit. • Internal parts are wet 	<ul style="list-style-type: none"> • Clean the unit according to instructions • If operating the unit under humid conditions, turn it off and wait for it to dry until resuming operation.

CLEANING & MAINTENANCE

This ION401 runs quietly and produces clean, fresh and healthy air. If your product becomes noisy, this generally indicates that it needs to be cleaned.

Caution:

- Always disconnect this product from its power supply before detaching or installing any parts.
- The Dust Collection Blades cannot be detached without first releasing the lock. Do not use excessive force to pull out the blades to prevent damaging the product.
- To prevent damaging the unit, always allow the dust collection blades to dry thoroughly before re-inserting into their original position in the unit.

Recommendations:

In order to keep the unit working properly, we highly recommend the following measures:

- Clean the Dust Collection Blades once every 3 to 4 days.
- Clean the Ionising Wires once a week or when the unit becomes noisy.
- If your ION401 operates in a heavily polluted environment, make sure to clean it more frequently.

CLEANING INSTRUCTIONS

Cleaning the Dust Collection Blades.

1. Hold the handle, as shown in **Figure 1** (following page).
2. Next, pull the sliding lock button (see **Figure 2 part B**) and lift the handle gently upward (see **Figure 2 part A**).
3. Place the blades on the ground or floor, leaving them for 10 minutes to discharge any static currents.
4. Wipe away the trapped particles on the blades with a damp sponge or cloth. Mild detergent and water may be used if necessary. *Note: If detergent and water are used, you must wait at least 24 hours for the blades to dry completely.*
5. Leave your unit to dry for 2 to 3 hours.

CLEANING INSTRUCTIONS

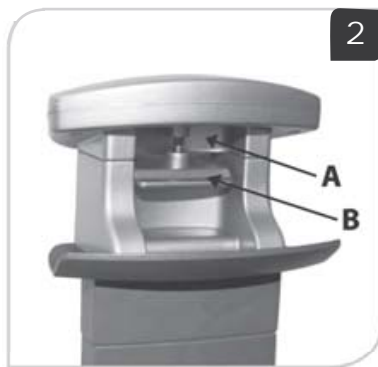

Inserting the Dust Collection Blades

After your blades are clean and dry, vertically re-insert the blades into their correct position, as show in Figure 4. Note: if you use a combination of water and a cleaning product, you must wait at least 24 hours for the blades to completely dry.

Cleaning the Ionising Wires

Each strand of ionising wire is equipped with a dust removal mechanism and must be cleaned once a week, or when the unit becomes noisy.

1. Lift the Cleaning Rod (see **Figure 4 Part C**)
2. Pull the Cleaning Rod up and push it down several times to remove the dust on the Ionising Wires.
3. Return the Cleaning Rod to its original position by lightly pushing it into place.



WARRANTY DETAILS

Congratulations on your purchase! It is our aim to provide you with quality products that you can trust. Our products come with guarantees that cannot be excluded under the Australian Consumer Law. You are entitled to a replacement or a refund for a major failure and for compensation for any other reasonably foreseeable loss or damage.

You are also entitled to have the goods repaired or replaced if the goods fail to be of acceptable quality and the failure does not amount to a major failure.

The Guarantee

The product is guaranteed to be free from defects in workmanship and parts for a period of 12 months from date of purchase for domestic use and 3 months for commercial use. Defects that occur within this warranty period, under normal use and care, will be repaired, replaced or refunded at our discretion, solely at our option with no charge for parts and labour. The benefits conferred by this warranty are in addition to all rights and remedies in respect of the product that the consumer has under the Trade Practises Act and similar state laws.

Proof of Purchase

This warranty is valid for the original purchase and is not transferable. Please keep your purchase docket or receipt as proof of purchase and as proof of date on which the purchase was made. The purchase docket (or a copy) or receipt must be presented with the warranty when making a claim under this warranty.

Service during the Warranty Period

Please ensure that the RA# (Return Authorization Number) is clearly stated on the outside of the packaging. Don't have one? Email us at support@andatech.com.au or call us on 1300 900 200. Please ensure the product is properly packaged to ensure that no damage occurs during transit.

Extent of Warranty

This warranty is limited to defects in workmanship or parts. All defective products or parts will be repaired or replaced. This warranty does not cover manuals and packaging.

Normal Wear and Tear

This warranty does not cover normal wear and tear to the product or parts.

Exclusions

This warranty does not cover:

- Any defect caused by an accident, misuse, abuse, improper operation, lack of reasonable care, unauthorised modification, loss of parts, tampering or attempted repair by a person not authorised by the distributor.
- Any product that has been damaged by a lightning strike either directly or indirectly or a mains power surge or liquid ingress.
- The product if it is located outside of Australia.
- Any damage caused by improper power input or improper cable connection.

Andatech Corporation Pty. Ltd.

PO BOX 3038 Nunawading VIC 3131

Phone: 1300 800 200 Fax: 1300 883 802 Email: info@andatech.com.au

1
YEAR
WARRANTY

WARRANTY REGISTRATION

Register your warranty at my.andatech.com.au.

OR

Simply fill out this form and post it with a copy of the receipt to:

Andatech Corporation Pty Ltd
PO Box 3038, Nunawading VIC 3131, Australia.

Product **Ionmax Ion401**

Date of purchase.....

Place of purchase.....

Serial no.....

Surname.....

Given name.....

Address.....

Suburb.....

Postcode.....

State.....

Contact no.....

Email.....





www.ionmax.com.au

1300 800 200